

The **GSD52 Slim-Line Sliding Door System** is versatile in both construction and design.

Its slim top rail is only 51 mm tall and comprises a single piece of extruded aluminium track with a clip-on cover and two end caps. Both the track and cover are available in brushed aluminium and satin anodised finishes.

Three independent rollers attached to the clamps offer a smooth rolling motion and prevent the clamp assembly from jumping off the track. A hydraulic damper within the track acts as a soft-closing mechanism to prevent sliding door impact.

The GSD52 can be wall mounted or ceiling mounted. The robust clamping and roller system can support glass panels weighing up to 80 kg and is suited to 8 mm, 10 mm, 12 mm & 13.52 mm thick glass.

The GSD52 Slim-Line Sliding Door System is easy to install and economical. There is no need for any glass clamping notch preparation. Coupled with its slim sightline, the GSD52 is an ideal solution for every designer and installer.

CAT. NO.	DESCRIPTION	SIZE	COLOUR
<a href="#">GSD522MK1TB</a>	GSD Kit with Soft Close	2000 mm	Brushed Aluminium
<a href="#">GSD522MK1TSA</a>	GSD Kit with Soft Close	2000 mm	Satin Anodized
<a href="#">GSD523MK1TB</a>	GSD Kit with Soft Close	3000 mm	Brushed Aluminium
<a href="#">GSD523MK1TSA</a>	GSD Kit with Soft Close	3000 mm	Satin Anodized
<a href="#">GSD524MK1TB</a>	GSD Kit with Soft Close Bi Parting	4000 mm	Brushed Aluminium
<a href="#">GSD524MK1TSA</a>	GSD Kit with Soft Close Bi Parting	4000 mm	Satin Anodized
<a href="#">GSD522MFPK1TB</a>	GSD Kit with Soft Close and Fixed Panel	2000 mm	Brushed Aluminium
<a href="#">GSD522MFPK1TSA</a>	GSD Kit with Soft Close and Fixed Panel	2000 mm	Satin Anodized
<a href="#">GSD523MFPK1TB</a>	GSD Kit with Soft Close and Fixed Panel	3000 mm	Brushed Aluminium
<a href="#">GSD523MFPK1TSA</a>	GSD Kit with Soft Close and Fixed Panel	3000 mm	Satin Anodized

# GSD52 SLIM-LINE SLIDING DOOR SYSTEM

## COMPONENTS

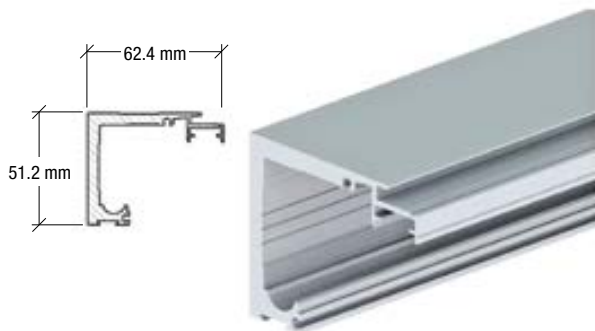

**1** GSD52TR  
Aluminium Top Track

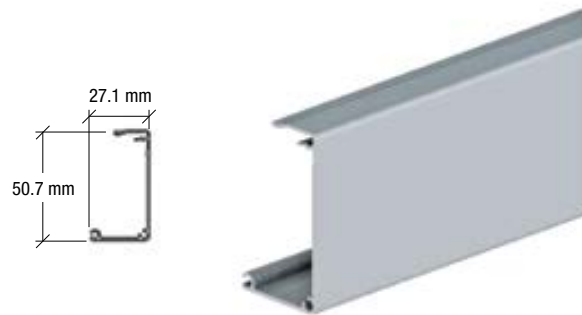

**2** GSD52FC  
Aluminium Clip-on Cover



**3** GSD52CR3  
Three Wheels Carriage Roller with Hook



**4** GSD52HY72  
Hydraulic Damper



**5** GSD52EC  
End Cap



**6** CRL3978 - Satin Anodised  
LS307BS - Brushed Aluminum  
Single-U Stainless Steel Floor Guide

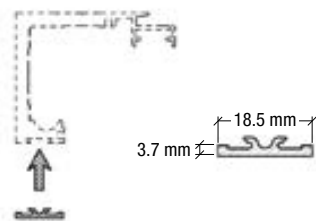

**7** GSD1FCPB  
Aluminium Cover Piece

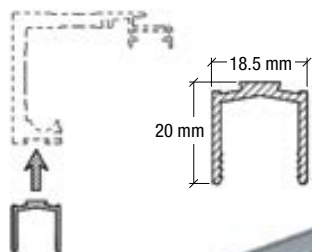

**8** GSDTC  
Dovetailed U-Channel

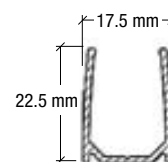

**9** GSDBC  
Bottom U-Channel

## WALL MOUNT SLIDING DOOR SYSTEM

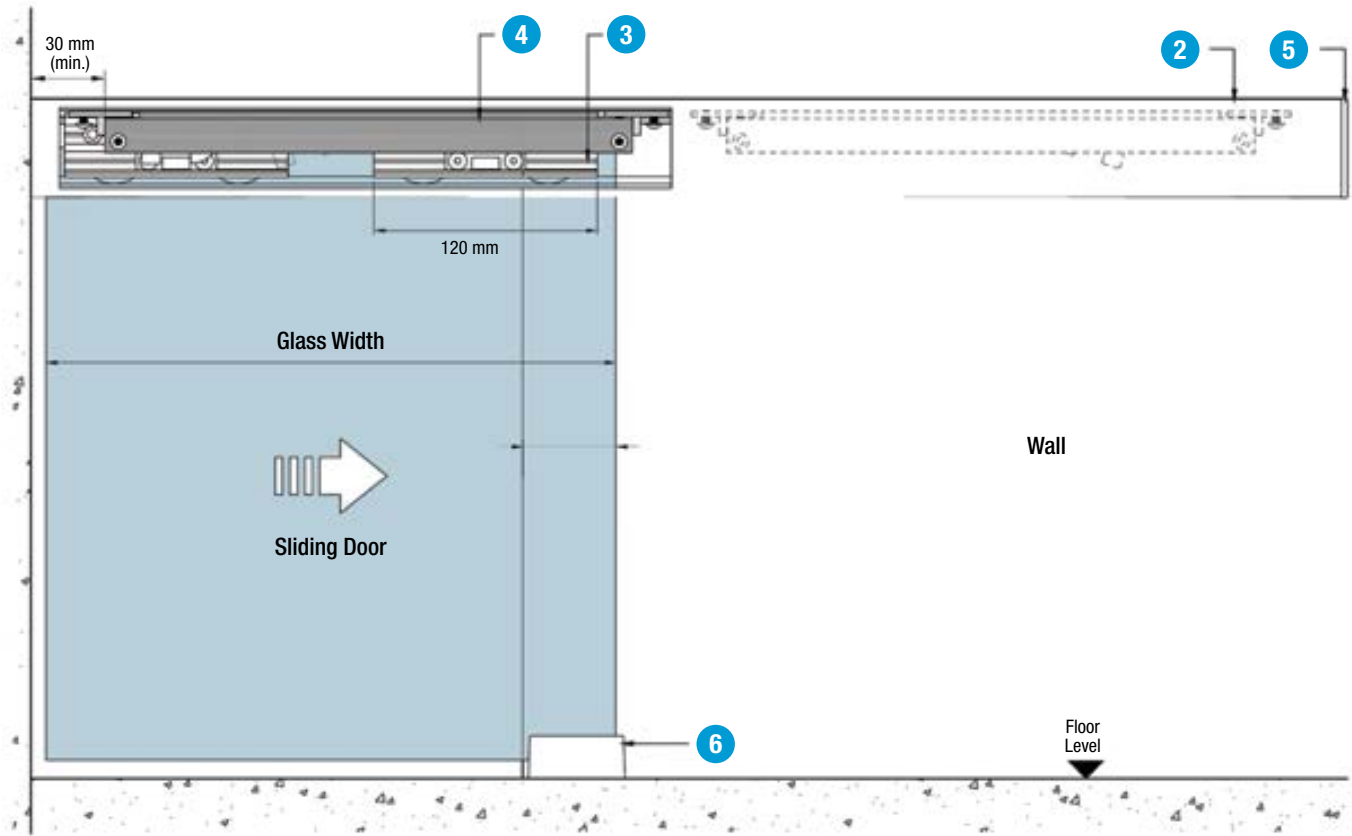

GSD52 Wall Mounted Sliding Door System is available with the following standard components as a complete system:

- 1 GSD52TR Aluminium top track
- 2 GSD52FC Clip-on aluminium cover
- 3 GSD52CR3 Three wheels carriage rollers glass clamp with hook
- 4 GSD52HY72 Hydraulic damper
- 5 GSD52EC End cap (LH&RH)
- 6 CRL3978/ LS307BS Single-U floor guide
- 7 GSD1FCPB Aluminium cover piece

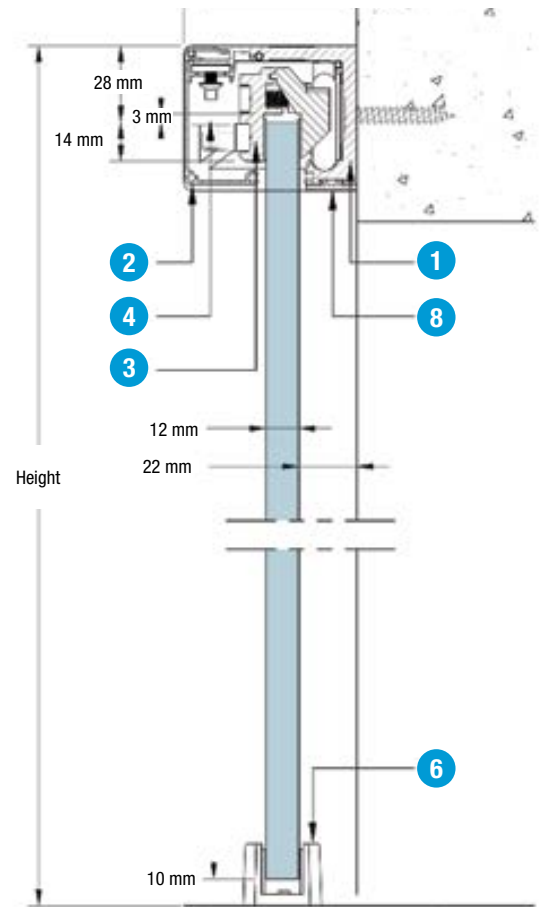

\*\*Glass Door Height = Height - 40 mm

# GSD52 SLIM-LINE SLIDING DOOR SYSTEM

## CEILING MOUNTED SLIDING DOOR SYSTEM WITH FIXED PANEL

GSD52 Wall Mounted Sliding Door System is available with the following standard components as a complete system:

- 1 GSD52TR Aluminium top track
- 2 GSD52FC Clip-on aluminium cover
- 3 GSD52CR3 Three wheels carriage rollers glass clamp with hook
- 4 GSD52HY72 Hydraulic damper
- 5 GSD52EC End cap (LH&RH)
- 6 CRL3978/ LS307BS Single-U floor guide

Ceiling Mounth with  
Fixed Glass Panel Below Track

- 9 GSDTC Dovetailed U-Channel
- 10 GSDBC Bottom U-Chanel

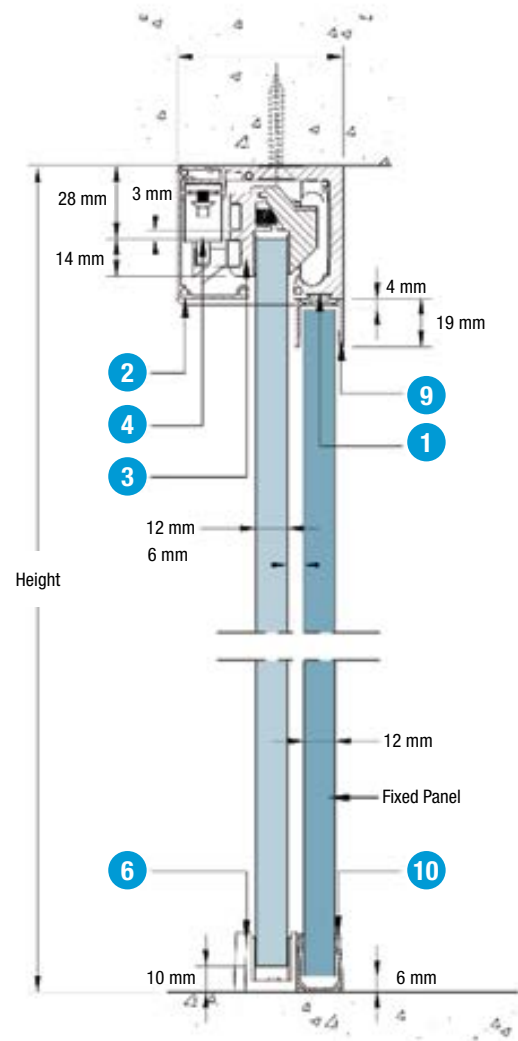

\*\*Glass Door Height = Height - 40 mm

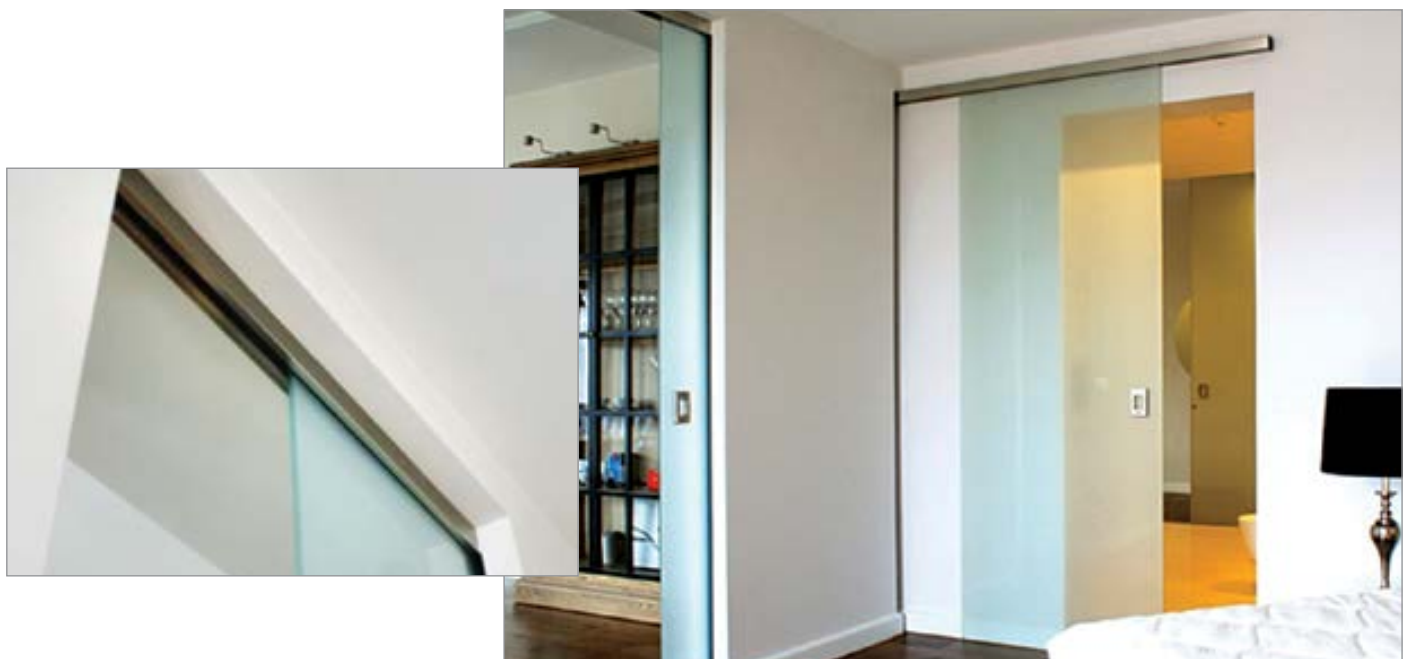

AVDB4349\_6.19